

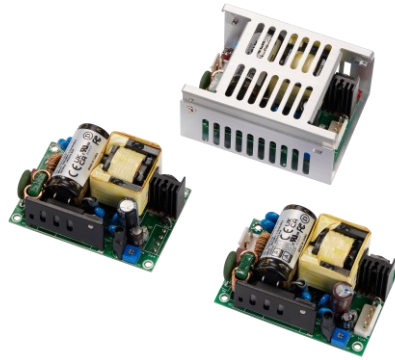

# CFM81S SERIES 80 WATT OPEN FRAME AC-DC MODULES

## Features

- Universal Input Range 90~264Vac
- High Efficiency up to 91%
- 2"x 3" Open Frame Compact Size
- Class I and Class II
- No Load Power <0.3W  
CFM81S480 No Load Power <0.35W
- Approval IEC/EN/UL 62368-1 Ed 3.0
- Approval IEC/EN 60335-1(For Wafer Versions)
- Approval EN 55032 Class B  
and CISPR/FCC Class B
- Operating Altitude 5000m
- Continuous Short Circuit Protection
- Peak Load (2 Times of Rated Current (note7))



MODEL NUMBER	OUTPUT VOLTAGE	OUTPUT CURRENT	VOLTAGE ACCURACY NOTE1	RIPPLE & NOISE NOTE2	VOLTAGE ADJ. RANGE	LINE REGULATION NOTE3	LOAD REGULATION NOTE4	%EFF. (Typ.) NOTE5
CFM81S120	12 V	6.7 A	±1%	120 mV	11.4~12.6 V	±0.5%	±1%	89%
CFM81S150	15 V	5.36 A	±1%	150 mV	14.25~15.75 V	±0.5%	±1%	89%
CFM81S240	24 V	3.35 A	±1%	240 mV	22.8~25.2 V	±0.5%	±1%	90%
CFM81S480	48 V	1.67 A	±1%	480 mV	45.6~50.4 V	±0.5%	±1%	91%

Note:

1. Voltage accuracy is set at 100% full load.
2. Add a 0.1uF ceramic capacitor and a 10uF E.L. capacitor to output for ripple & noise measurement @20MHz BW.
3. Line regulation is measured from 90V<sub>ac</sub> to 264V<sub>ac</sub> with 100% full load.
4. Load regulation is measured from 10% to 100% full load.
5. Typical efficiency at 230 V<sub>ac</sub> and 100% full load at 25°C.
6. Standard input and output connectors (CN1 and CN2) wafer with TAIWAN KING PIN TERMINAL PVHI series and mate with JST housing VHR series and JST SVH-21/41T-P1.1 series crimp terminal.
7. PL (peak load function) lasting time < 10 seconds with a maximum 10% duty cycle.

## PART NUMBER

Series	Number of Outputs	Nominal Output Voltage	Type
CFM81	X	XX	-XX (Option)
CFM81	S : Single	120 : 12V 150 : 15V 240 : 24V 480 : 48V	Blank : Wafer P : PCB Mount CA : Cover

Part Number Example:

**CFM81S120-P**: Open Frame, 80W, Single 12Vdc Output, PCB Mount



# CFM81S Series

## TECHNICAL SPECIFICATIONS

(All specifications are typical at nominal input, full load at 25°C unless otherwise noted.)

### ABSOLUTE MAXIMUM RATINGS

PARAMETER	NOTES and CONDITIONS	Device	Min.	Typ.	Max.	Units
Input Voltage	Safety approvals only to the AC input	All	90		264	V <sub>ac</sub>
				120		370
Operating Temperature	See Derating Curve	All	-30		80	°C
Storage Temperature		All	-30		85	°C
Operating Altitude	IEC/EN/UL 62368-1 IEC/EN 60335-1	All			5000	m

### INPUT CHARACTERISTICS

PARAMETER	NOTES and CONDITIONS	Device	Min.	Typ.	Max.	Units
Operating Voltage Range		All	100		240	V <sub>ac</sub>
Input Frequency Range		All	50		60	Hz
Maximum Input Current	100% Load, V <sub>in</sub> =100V <sub>ac</sub>	All			1.7	A
Leakage Current		All			0.25	mA
Inrush Current	V <sub>in</sub> =240V <sub>ac</sub> , Cold start at 25°C	All			100	A

### OUTPUT CHARACTERISTICS

PARAMETER	NOTES and CONDITIONS	Device	Min.	Typ.	Max.	Units
Output Voltage Set Point	V <sub>in</sub> =90V <sub>ac</sub> ~264V <sub>ac</sub> , I <sub>o</sub> =I <sub>o</sub> max., T <sub>c</sub> =25°C	CFM81S120	11.88	12	12.12	V <sub>dc</sub>
		CFM81S150	14.85	15	15.15	
		CFM81S240	23.76	24	24.24	
		CFM81S480	47.52	48	48.48	
Operating Output Current Range	V <sub>in</sub> =90V <sub>ac</sub> ~264V <sub>ac</sub> , See Derating Curve	CFM81S120			6.7	A
		CFM81S150			5.36	
		CFM81S240			3.35	
		CFM81S480			1.67	
Holdup Time	V <sub>in</sub> =115V <sub>ac</sub>	All		12		ms
Output Voltage Regulation						
Load Regulation	10% Load to full load	All			±1.0	%
Line Regulation	V <sub>in</sub> =High line to low line	All			±0.5	%
Over Voltage Protection	Built-in a TVS component to clamp output voltage	CFM81S120			16.2	V <sub>dc</sub>
		CFM81S150			18.9	
		CFM81S240			31.5	
		CFM81S480			58.8	
Output Ripple and Noise	1. Add a 0.1uF ceramic capacitor and a 10uF aluminum electrolytic capacitor to output 2. Oscilloscope is 20MHz band width 3. Ambient temperature=25°C	CFM81S120			120	mV
		CFM81S150			150	
		CFM81S240			240	
		CFM81S480			480	
Load Capacitance	1. V <sub>in</sub> =115V <sub>ac</sub> and 230V <sub>ac</sub> 2. Output is max. load 3. Ambient temperature=25°C	CFM81S120			13400	uF
		CFM81S150			11000	
		CFM81S240			6700	
		CFM81S480			3340	
Efficiency	1. Input voltage is 230V <sub>ac</sub> 2. Output is rated load 3. Ambient temperature=25°C	CFM81S120		89		%
		CFM81S150		89		
		CFM81S240		90		
		CFM81S480		91		



# CFM81S Series

## ISOLATION CHARACTERISTICS

PARAMETER	NOTES and CONDITIONS	Device	Min.	Typ.	Max.	Units
Input to Output	1 Minute	All			3000	V <sub>ac</sub>
Isolation Resistance	Input to output	All	100			MΩ

## FEATURE CHARACTERISTICS

PARAMETER	NOTES and CONDITIONS	Device	Min.	Typ.	Max.	Units
Switching Frequency	P <sub>out</sub> =max. rated power	All		65		kHz

## GENERAL SPECIFICATIONS

PARAMETER	NOTES and CONDITIONS	Device	Min.	Typ.	Max.	Units
MTBF	I <sub>o</sub> =100%; T <sub>a</sub> =25°C per MIL-HDBK-217F I <sub>o</sub> =100%; T <sub>a</sub> =25°C Telcordia SR332	All	410 3100	580		k hours
Humidity	Non-condensing	All			93	% RH
Shock	Meet MIL-STD-810F Table 516.5, Table 516.5-I 10ms, each axis 3 times(±X · ±Y · ±Z axis)	All		75		g
Vibration	Meet MIL-STD-810F Table 514.5C-VIII, 15~2000Hz, X · Y · Z axis, 1 hour (each axis),. Total 3 hrs.	All		4		g
Weight		CFM81S CFM81S-P CFM81S-CA		135 133 174		grams
Dimensions	Open Frame (Wafer)	All	3.000x2.000x1.339 Inches (76.20x50.80x34.00 mm)			
	P (PCB Mount)		3.000x2.000x1.413 Inches (76.20x50.80x35.90mm)			
	CA (Cover)		3.200x2.441x1.575 Inches (81.28x62.00x40.00mm)			
Safety	Class I, Class II, IEC/EN/UL 62368-1 (Ed 3.0), IEC/EN 60335-1 (For Wafer Versions)					
EMC Emission	EN 55032 Class B, 47 CFR FCC Part 15 Subpart B, Oct.2014 EN 61000-3-2:2019, EN 61000-3-3:2013+A1:2019, EN 61000-6-3:2021, EN 61000-6-4:2019, EN 61204-3:2018					Class B
Conducted Disturbance	EN 55032, EN 61204-3:2018, EN 61000-6-3:2021, EN 61000-6-4:2019, Class B, 47 CFR FCC Part 15 Subpart B					Class B
Radiated Disturbance	EN 55032, EN 61204-3:2018, EN 61000-6-3:2021, EN 61000-6-4:2019, Class B, 47 CFR FCC Part 15 Subpart B					Class B
Harmonic Current Emissions	EN 61000-3-2:2019					
Voltage Fluctuations & Flicker	EN 61000-3-3:2013+A1:2019					
EMC Immunity	EN 55035, EN 61204-3:2018, EN 61000-6-1:2019, EN 61000-6-2:2019					
Electrostatic Discharge (ESD)	IEC 61000-4-2:2008, Air Discharge: ±8kV, Contact Discharge: ±4kV				Criterion A	
Radio-Frequency, Continuous Radiated Disturbance	IEC 61000-4-3:2020				Criterion A	
Electrical Fast Transient (EFT)	IEC 61000-4-4:2012, ±1kV, ±2kV				Criterion A	
Surge	IEC 61000-4-5:2014+A1:2017, L-N: ±0.5kV, ±1kV, L-E(Ground): ±0.5kV, ±1kV, ±2kV				Criterion A	
Conducted Disturbances, Induced by RF Fields	IEC 61000-4-6:2013+COR1:2015				Criterion A	
Power Frequency Magnetic Field	IEC 61000-4-8:2009				Criterion A	
Voltage Dips	IEC 61000-4-11:2020, Dip: 30% Reduction, Dip >95% Reduction				Criterion A	
Voltage Interruptions	IEC 61000-4-11:2020, >95% Reduction				Criterion B	
Application Note Link	<a href="#">CFM81S Series App Notes</a>					



# CFM81S Series

## CHARACTERISTIC CURVE

### Power Derating Curve

Peak Load Vin De-Rating

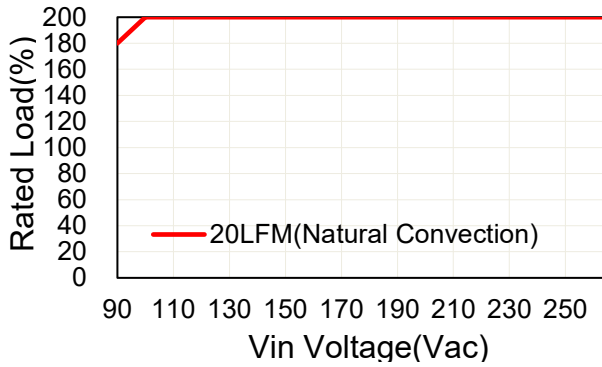

Power Derating

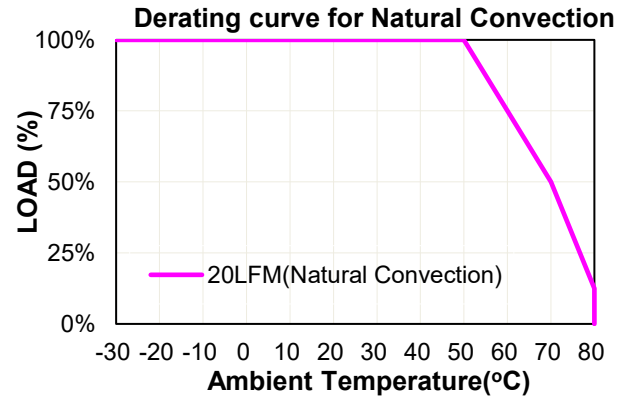

CFM81S120-CA

Derating Curve for Natural Convection

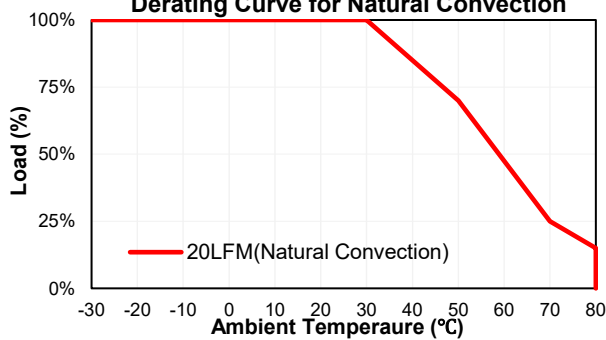

CFM81S150/240/480-CA

Derating Curve for Natural Convection

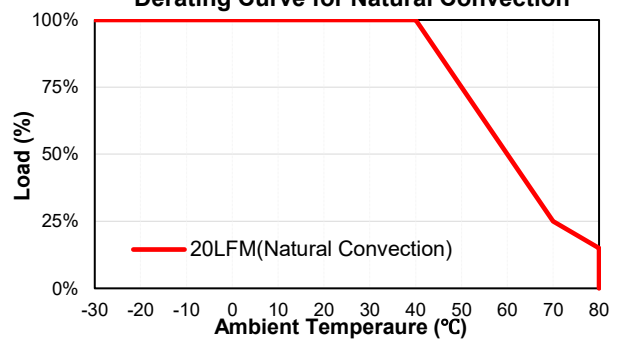

### Performance Data

CFM81S120 (Eff Vs Io)

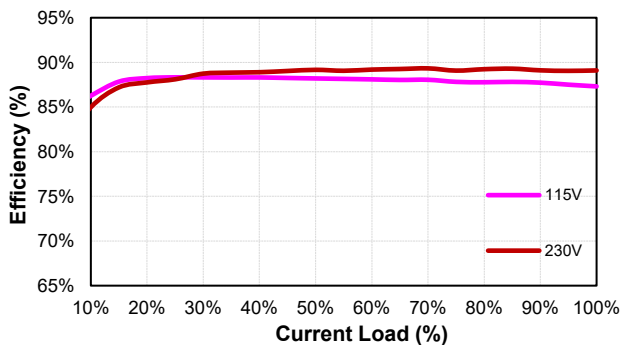

CFM81S150 (Eff Vs Io)

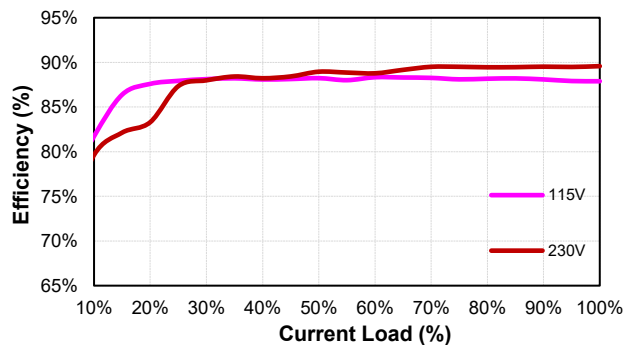



# CFM81S Series

CFM81S240 (Eff Vs Io)

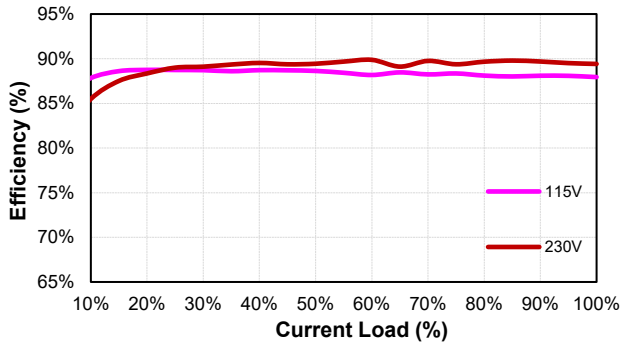

CFM81S480 (Eff Vs Io)

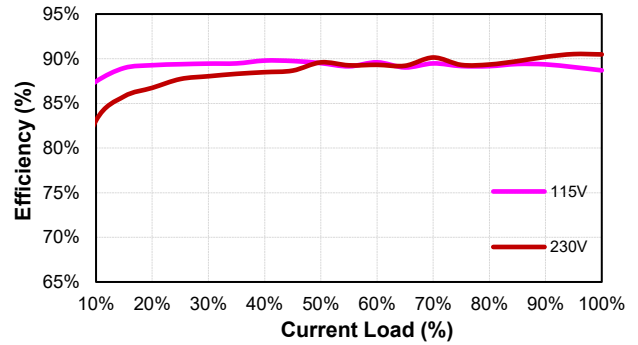

## MECHANICAL SPECIFICATION

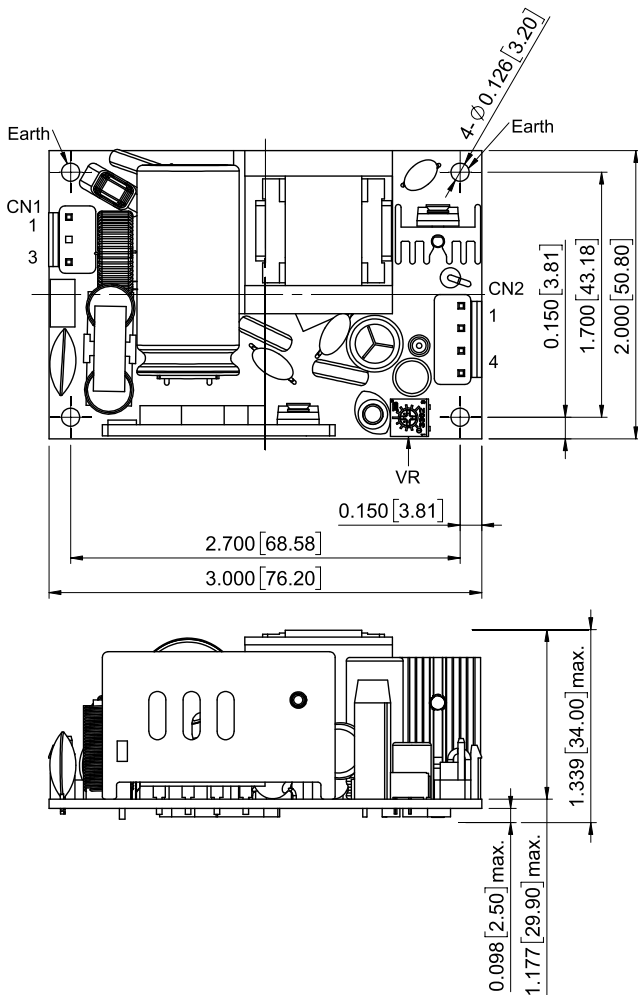

## CFM81SXXX

All Dimensions in Inches[mm]  
 Tolerance Inches: x.xx=±0.03, x.xxx=±0.020  
 Millimeters: x.x=±0.7, x.xx=±0.50

AC Input Connector(CN1):TKP PVHI-03N2 or equivalent

Pin	Function	Mating Housing	Terminal
1	ACN	JST VHR-3N or equivalent	JST SVH-21T-P1.1 or equivalent
2	-		
3	ACL		

DC Output Connector(CN2):TKP PVHI-04 or equivalent

Pin	Function	Mating Housing	Terminal
1	-Vout	JST VHR-4N or equivalent	JST SVH-21T-P1.1 or equivalent
2	-Vout		
3	+Vout		
4	+Vout		



# CFM81S Series

## MECHANICAL SPECIFICATION

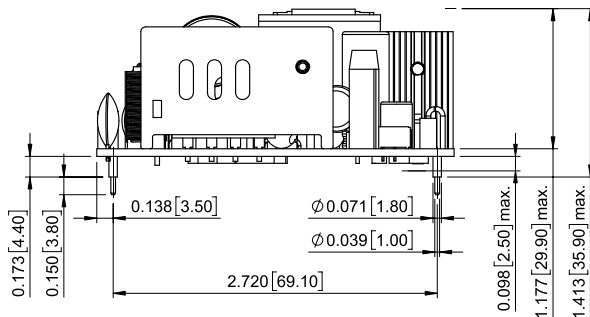
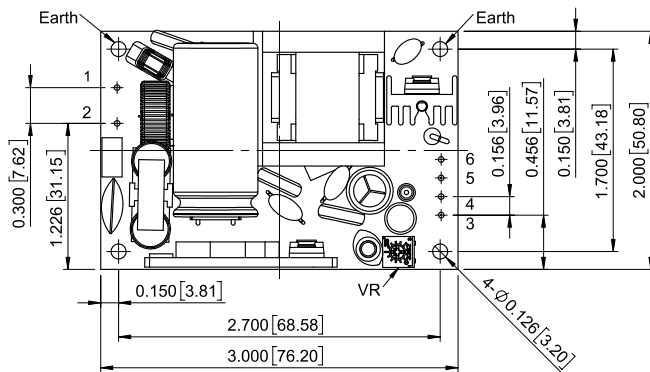
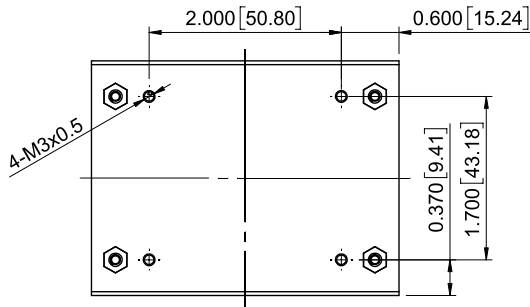
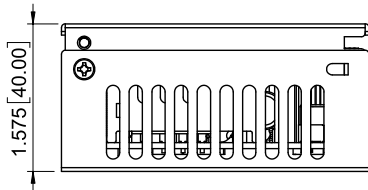
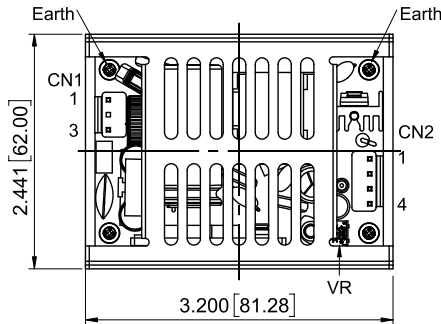

### CFM81SXXX-CA

All Dimensions in Inches[mm]  
Tolerance Inches: x.xx=±0.03, x.xxx=±0.020  
Millimeters: x.x=±0.7, x.xx=±0.50

AC Input Connector(CN1):TKP PVHI-03N2 or equivalent

Pin	Function	Mating Housing	Terminal
1	ACN	JST VHR-3N or equivalent	JST SVH-21T-P1.1 or equivalent
2	-		
3	ACL		

DC Output Connector(CN2):TKP PVHI-04 or equivalent

Pin	Function	Mating Housing	Terminal
1	-Vout	JST VHR-4N or equivalent	JST SVH-21T-P1.1 or equivalent
2	-Vout		
3	+Vout		
4	+Vout		

### CFM81SXXX-P

All Dimensions in Inches[mm]  
Tolerance Inches: x.xx=±0.03, x.xxx=±0.020  
Millimeters: x.x=±0.7, x.xx=±0.50

Pin Connection	
Pin	Function
1	ACN
2	ACL
3	+Vout
4	+Vout
5	-Vout
6	-Vout

CINCON Electronics Co. Ltd.  
Add: 14F, No. 306, Sec.4, Hsin Yi Rd., Taipei, Taiwan  
Tel: 886-2-27086210  
Fax: 886-2-27029852  
E-mail: [sales@cincon.com](mailto:sales@cincon.com)  
Web: [www.cincon.com](http://www.cincon.com)